

PRECISION PRESSURE REGULATORS

	DESCRIPTION	PRESSURE RANGE bar	CONNECTION thread	DEVICE	PAGE
WITH CONSTANT BLEED	miniature	0.05 ... 2 / 8	G $\frac{1}{8}$	RI	5.02
	miniature	0.05 ... 2 / 8	G $\frac{1}{8}$ and flange	R90	5.03
	proven	0.02 ... 0.5 / 10	G $\frac{1}{4}$	11-818	5.06
	proven	0.14 ... 1.7 / 8	G $\frac{1}{4}$ and $\frac{1}{4}$ "NPT	53.10	5.07
	very precise	0.01 ... 0.14 / 28	G $\frac{1}{4}$ - G $\frac{1}{2}$	10	5.08
	many variations	0.01 ... 0.14 / 10	G $\frac{1}{4}$ - G $\frac{1}{2}$	R230	5.09
	small design	0.001 ... 0.14 / 7	G $\frac{1}{4}$ and G $\frac{3}{8}$	R300	5.10
	Nullmatic	0.002 ... 0.12 / 31	$\frac{1}{4}$ "NPT	R40	5.12
	high ventilation	0.01 ... 3 / 10	G $\frac{1}{4}$ - G $\frac{1}{2}$	R03	5.14
	low pressure	0.002 ... 0.35 / 0.8	G $\frac{1}{4}$ - G $\frac{1}{2}$	R110	5.15
	high volume flow	0.001 ... 0.7 / 10	G1 and G1 $\frac{1}{2}$	R102	5.16
	miniature	0.01 ... 0.35 / 7	M5 and flange	RT	1.10
	miniature	0.005 ... 0.05 / 1.5	G $\frac{1}{2}$	RR	3.10
	clean room environment, SST	0.05 ... 2 / 4	G $\frac{1}{8}$, M5	RE1	15.04
	stainless steel	0.02 ... 1.5 / 10	G $\frac{1}{4}$ and G $\frac{1}{2}$	R3150	15.05
WITHOUT CONSTANT BLEED	robust	0.01 ... 0.5 / 16	G $\frac{1}{4}$	R217	5.04
	robust, low cost	0.01 ... 0.6 / 3.5	G $\frac{1}{4}$ and G $\frac{3}{8}$	R216	5.05
	non-relieving	0.01 ... 0.14 / 28	G $\frac{1}{4}$ - G $\frac{1}{2}$	10-N	5.08
	non-relieving	0.01 ... 0.14 / 10	G $\frac{1}{4}$ - G $\frac{1}{2}$	R230-K	5.09
	small design	0.001 ... 0.14 / 7	G $\frac{1}{4}$ and G $\frac{3}{8}$	R300-K	5.10
	high volume flow	0.03 ... 0.7 / 10	G $\frac{1}{4}$ and G $\frac{3}{8}$	R100	5.11
	high-precision	0.03 ... 0.7 / 17	G $\frac{3}{8}$ - G $\frac{1}{2}$	R400	5.13
	non-relieving	0.002 ... 0.35 / 0.8	G $\frac{1}{4}$ - G $\frac{1}{2}$	R110-K	5.15
	non-relieving	0.001 ... 0.7 / 10	G1 and G1 $\frac{1}{2}$	R102-K	5.16
	differential pressure regulator	0.01 ... 1 / 10	G $\frac{1}{4}$ and G $\frac{3}{8}$	R650	6.02
	miniature	0.2 ... 2 / 9	flange	R342	1.14
	miniature	0.2 ... 2 / 9	G $\frac{1}{8}$ and G $\frac{1}{4}$	R344	1.14
	miniature	0.1 ... 3 / 6	G $\frac{1}{8}$	R309	1.16
	miniature	0.2 ... 2.5 / 8	G $\frac{1}{8}$	R307	1.18
	miniature	0.2 ... 0.25 / 8	flange	R308	1.19



5

Precision



5

MINIATURE PRECISION PRESSURE REGULATOR ∇ 35 MM

RI

Description	Diaphragm precision pressure regulator of very small design and low air consumption
Media	compressed air or non-corrosive gases
Supply pressure	max. 10 bar
Accuracy	response sensitivity: $\pm 0.2\%$ FS reproducibility: $\pm 0.5\%$ FS
Air consumption	max. 5 l/min at 10 bar supply pressure. Consumption depends on supply pressure.
Adjustment	by handwheel with locknut
Relieving function	relieving
Gauge port	G $\frac{1}{8}$ on both sides of the body, screw plug supplied
Mounting position	any
Temperature range	0 °C to 60 °C / 32 °F to 140 °F
Material	Body: zinc die-cast Elastomer: NBR/Buna-N Inner valve: stainless steel and brass

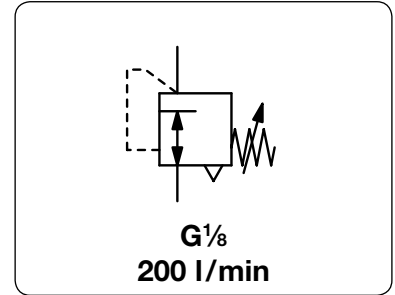

Dimensions			Flow rate	Supply pressure	Connection thread	Pressure range	Order number
A	B	C	l/min*1	max. bar	G	bar	
mm	mm	mm					

Precision pressure regulator	supply pressure max. 10 bar, relieving, with constant bleed, with mounting nut	RI
35 90 10 200 10 G $\frac{1}{8}$ 0.05...2		RI-01A
		RI-01B
		RI-01C



RI-01, with mounting nut
accessory: gauge

Accessories, enclosed

pressure gauge	\varnothing 23 mm, 0...*2 bar, G $\frac{1}{8}$	MA2301-...*2
mounting bracket	made of steel, mounting nut at the device	BW10-02

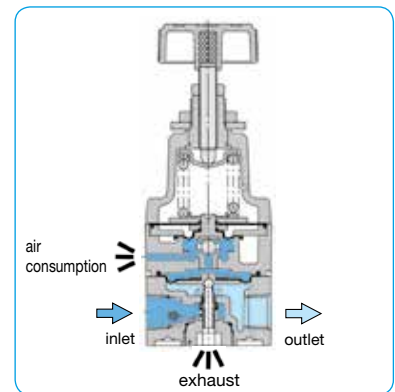

cross-section

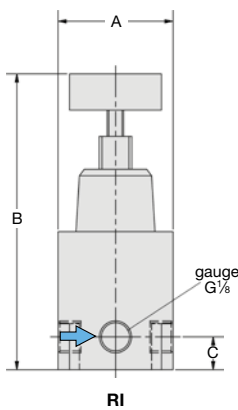

RI

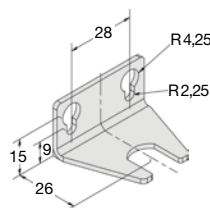

BW10-02

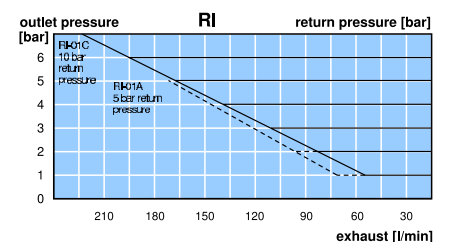
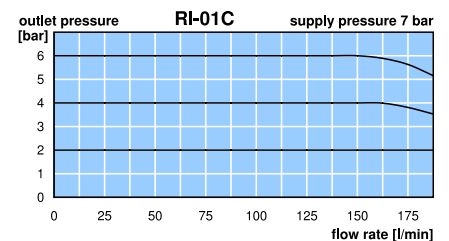
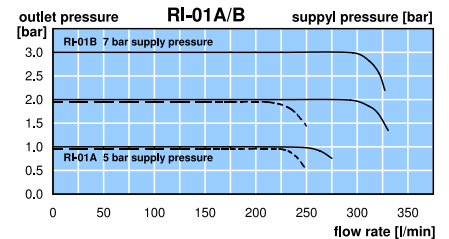

*1 for compressed air: 7 bar supply pressure, 6 bar outlet pressure and 1 bar pressure drop
*2 04 = 0...4 bar, 10 = 0...10 bar

Gauges: see chapter for measuring devices

PDF CAD
www.aircom.net

Order example:
RI-01A

Description Diaphragm precision pressure regulator of very small design and low air consumption compressed air or non-corrosive gases

Media max. 10 bar

Supply pressure response sensitivity: $\pm 0.2\%$ FS

Accuracy repeatability: $\pm 0.3\%$ FS

Air consumption supply sensitivity: 35 mbar for a 7 bar supply pressure change

Adjustment max. 3 l/min at 10 bar supply pressure. Consumption depends on supply pressure.

Relieving function by handwheel with locknut

Gauge port relieving

Mounting position G $\frac{1}{8}$ on both sides of the body, screw plug supplied

Temperature range any

Material 10 °C to 70 °C / 50 °F to 158 °F
 Body: zinc die-cast
 Elastomer: NBR/Buna-N
 Inner valve: stainless steel and brass

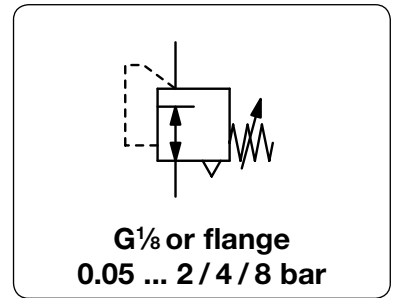

Dimensions			Flow rate	Supply pressure	Connection thread	Pressure range	Order number
A	B	C	l/min*1	max. bar	G / flange	bar	

Precision pressure regulator							supply pressure max. 10 bar, relieving, with constant bleed	R90
35	94	10	200	10	G $\frac{1}{8}$	0.05...2		R90-01A
						0.08...4		R90-01B
						0.10...8		R90-01C



R90

Precision pressure regulator with flange							supply pressure max. 10 bar, relieving, with constant bleed	R90-P
35	106	12	200	10	Flansch	0.05...2		R90-P1A
						0.08...4		R90-P1B
						0.10...8		R90-P1C



R90-P

Accessories, enclosed

- pressure gauge \varnothing 23 mm, 0...*2 bar, G $\frac{1}{8}$ **MA2301-...*2**
- mounting bracket made of steel, mounting nut at the device **BW10-02**

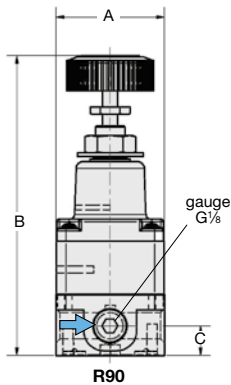
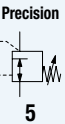

R90

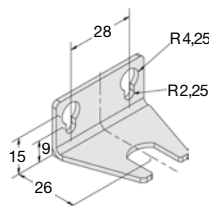

BW10-02

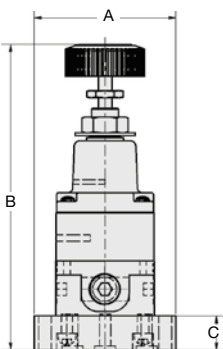

R90-P

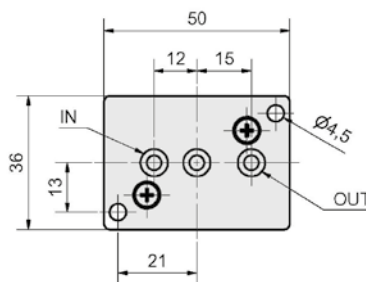

R90-P bottom view

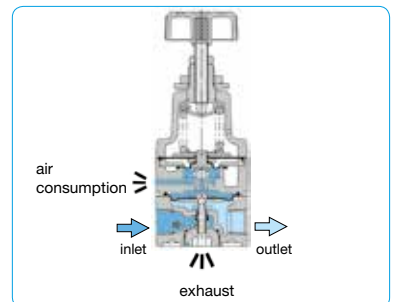

cross-section

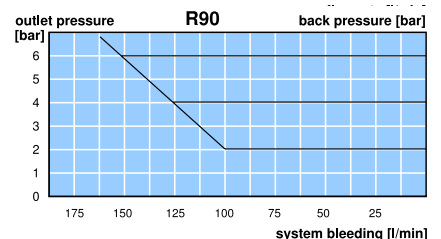
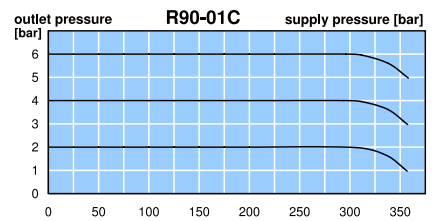

*1 for compressed air : 7 bar supply pressure, 6 bar outlet pressure and 1 bar pressure drop
 *2 04 = 0...4 bar, 10 = 0...10 bar

PRECISION REGULATOR WITHOUT CONSTANT BLEED, UP TO 16 BAR OUTLET PRESSURE R217

Description	Diaphragm pressure regulator with good regulation accuracy at varying volume flow.		
Media	compressed air or non-corrosive gases		
Supply pressure	max. 16 bar		
Accuracy	response sensitivity: < 350 mbar		
Air consumption	without constant bleed		
Adjustment	by handwheel with locknut, suitable for panel mounting		
Relieving function	relieving		
Gauge port	G $\frac{1}{4}$ on both sides of the body, one screw plug supplied		
Mounting position	any		
Temperature range	0 °C to 80 °C / 32 °F to 176 °F		
Material	Body: zinc die-cast	O-ring: NBR/Buna-N	
	Spring cage: zinc die-cast	Bottom screw: POM	
	Diaphragm: FKM		

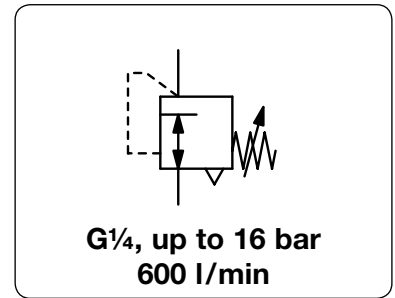

Dimensions			K _v -value (m ³ /h)	Flow rate m ³ /h*1 l/min*1	Connection thread G	Pressure range bar	Order number
A	B	C					

Precision pressure regulator							supply pressure max. 16 bar, relieving, without constant bleed	R217
82	148	20	0,3	36	600	G $\frac{1}{4}$	0,01 ... 0,5	R217-020
							0,01 ... 1	R217-02A
							0,20 ... 3	R217-02B
							0,40 ... 6	R217-02C
							0,50 ... 10	R217-02D
							0,70 ... 16	R217-02E

Special options, add the appropriate letter
 free of grease and oil specially cleaned R217-0..L



Accessories, enclosed
 pressure gauge Ø 63 mm, 0...*2 bar, G $\frac{1}{4}$ MA6302-...*2
 mounting bracket made of steel BW00-36

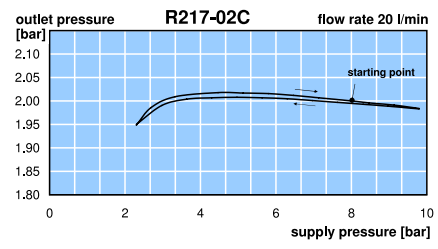
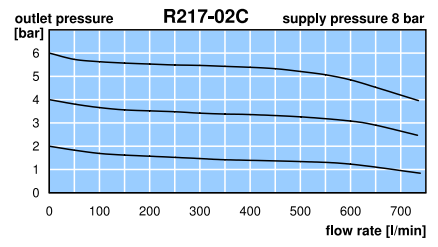
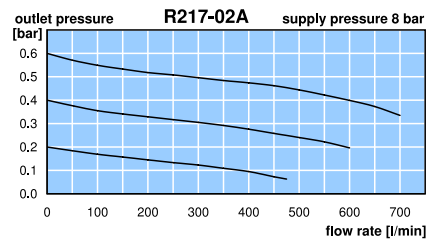
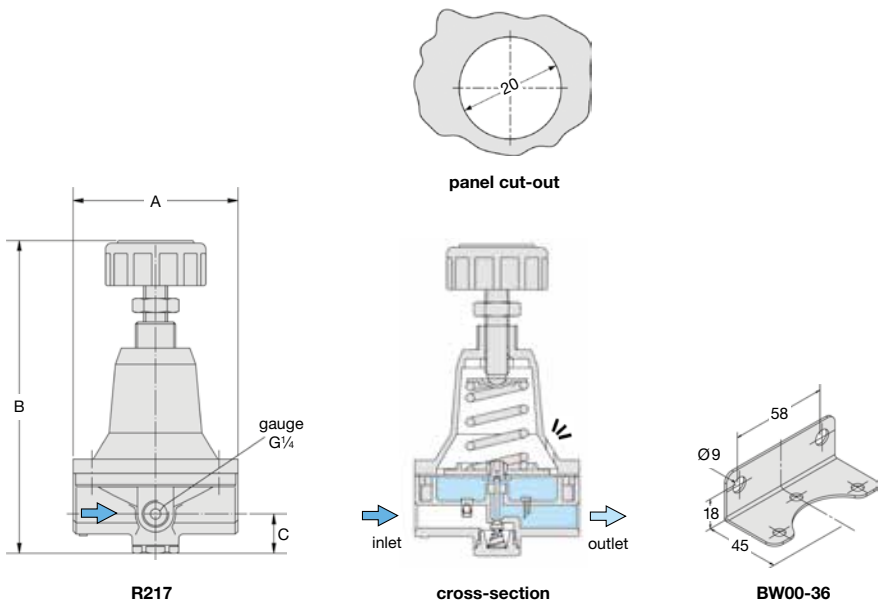
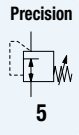

*1 at 8 bar supply pressure, 6 bar outlet pressure und 1 bar pressure drop
 *2 01 = 0...1 bar, 04 = 0...4 bar, 06 = 0...6 bar, 10 = 0...10 bar, 16 = 0...16 bar

PRECISION REGULATOR WITHOUT CONSTANT BLEED, UP TO 3.5 BAR OUTLET PRESSURE R216

Description	Diaphragm pressure regulator with good regulation accuracy at varying volume flow, especially at low pressure.		
Media	compressed air or non-corrosive gases		
Supply pressure	max. 21 bar		
Accuracy	response sensitivity: < 100 mbar		
Air consumption	without constant bleed		
Adjustment	by T-handle with locknut, mounting bracket not possible by handwheel, suitable for panel mounting		
Relieving function	relieving, optionally non-relieving		
Gauge port	G $\frac{3}{8}$ on the bottom side of the body, one screw plug supplied		
Mounting position	any		
Temperature range	0 °C to 50 °C / 32 °F to 122 °F for handwheel version 0 °C to 80 °C / 32 °F to 176 °F for T-handle version		
Material	Body: zinc die-cast	Elastomer: NBR/Buna-N	Bottom screw: brass

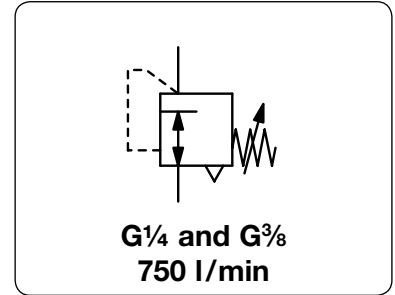

Dimensions			Adjustment	Kv-value	Flow rate		Connection thread	Pressure range	Order number
A	B	C	by	(m ³ /h)	m ³ /h*1	l/min*1	G	bar	

Precision pressure regulator									
supply pressure max. 21 bar, relieving, without constant bleed									
108	162	32	T-handle	0.39	42	700	G $\frac{1}{4}$	0.01 ... 0.6	R216-02E
								0.01 ... 1.6	R216-02F
								0.01 ... 3.5	R216-02H
				0.42	45	750	G $\frac{3}{8}$	0.01 ... 0.6	R216-03E
								0.01 ... 1.6	R216-03F
								0.01 ... 3.5	R216-03H
108	162	32	handwheel	0.39	42	700	G $\frac{1}{4}$	0.01 ... 0.6	R216-02EP
			for panel mounting					0.01 ... 1.6	R216-02FP
								0.01 ... 3.5	R216-02HP
				0.42	45	750	G $\frac{3}{8}$	0.01 ... 0.6	R216-03EP
								0.01 ... 1.6	R216-03FP
								0.01 ... 3.5	R216-03HP



Special options, add the appropriate letter

non-relieving	without relieving function	R216-0...K
NPT	connection thread	R216-0...N
free of oil and grease	specially cleaned	R216-0...L

Accessories, enclosed

pressure gauge	Ø 63 mm, 0... ² bar, G $\frac{1}{4}$, connection parts required	MA6302-...²
connection parts	for pressure gauge	AM-02
mounting bracket	made of steel, mounting nut at the device for R216-0...P	BW20-02

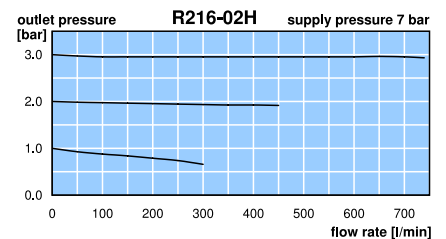
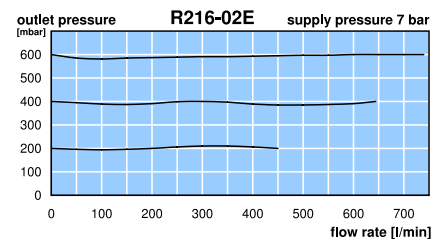
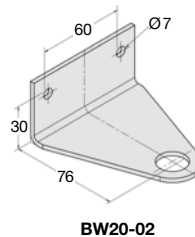
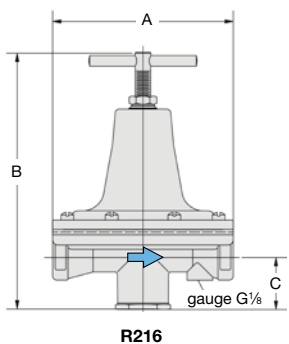
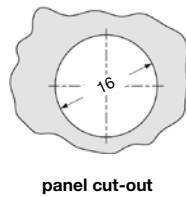
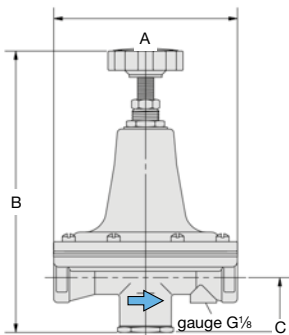

*1 at 7 bar supply pressure and 3 bar outlet pressure

*2 01 = 0...1 bar, 02 = 0...2,5 bar, 04 = 0...4 bar

Description	Precision pressure regulator designed for precise pressure control in the event of changes in flow and supply pressure. Due to constant bleed slight blow-off sounds existing.	
Media	dry, oil-free and 25 µm filtered compressed air	
Supply pressure	max. 8 bar for 0.02...0.5 bar, max. 10 bar for 0.07...4 bar, max. 14 bar for 0.4...10 bar	
Accuracy	at varying supply pressures: < 20 mbar pressure deviation at varying volume flows: < 30 mbar pressure deviation at 5 °C / K temperature variation: < 3 mbar pressure deviation	
Air consumption	max. 2 l/min, subject to outlet pressure	
Adjustment	by handwheel for panel mounting, optionally by spindle	
Relieving function	relieving, 3 mm exhaust diameter	
Gauge port	G¼ on both sides of the body, optionally without gauge port	Mounting position any
Temperature range	0 °C to 70 °C / 32 °F to 158 °F, for appropriately conditioned compressed air down to -30 °C / -22 °F	
Material	Body: zinc die-cast Elastomer: NBR/Buna-N	Inner valve: brass, plastic

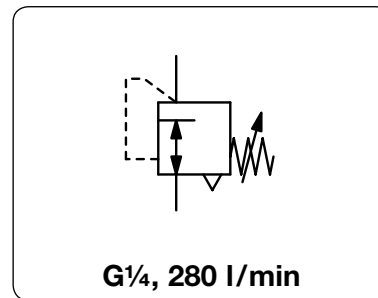

Dimensions			Description	P ₁ max.	Flow rate	Connection thread	Pressure range	Order number
A	B	C						
mm	mm	mm		bar	l/min*1	G	bar	

Precision pressure regulator			P1: max. 8 / 10 / 14 bar, relieving, with constant bleed, accuracy < 30 mbar, K _v = 0.16 m³/h					11-818
55	137	13	handwheel w/o gauge port	8	280	G¼	0.02 ... 0.5	11-818-999
				10			0.07 ... 4.0	11-818-100
				14			0.40 ... 10	11-818-110
55	137	13	handwheel w/o gauge port	8	280	G¼	0.02 ... 0.5	11-818-987
				10			0.07 ... 4.0	11-818-993
				14			0.40 ... 10	11-818-991
55	137	13	spindle w/o gauge port	8	280	G¼	0.02 ... 0.5	11-818-998
				10			0.07 ... 4.0	11-818-101
				14			0.40 ... 10	11-818-112



11-818-100

Special options, add the appropriate letter

tamper-proof cap made of brass, adjustment by screwdriver, total height 108 mm 11-818-...T

Accessories, enclosed

pressure gauge Ø 50 mm, 0...*2 bar, G¼ **MA5002-...*2**
mounting bracket made of steel, mounting nut at the device **BW12-01**
tamper-proof cap for metal sheet thickness from 2.5 up to 6 mm **3081-01**

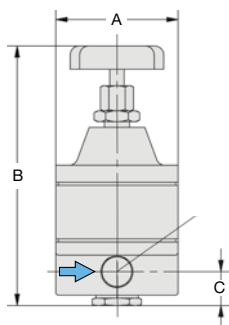
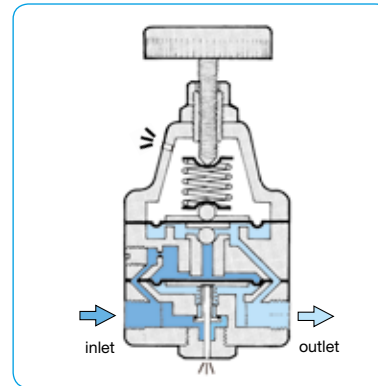

11-818

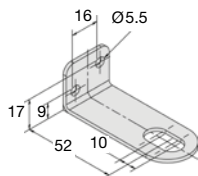

BW12-01



tamper-proof cap

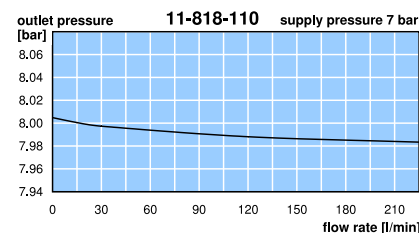
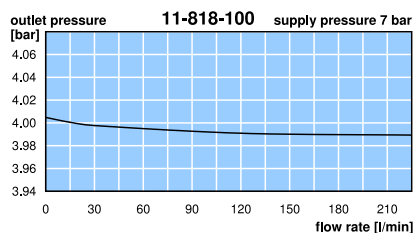
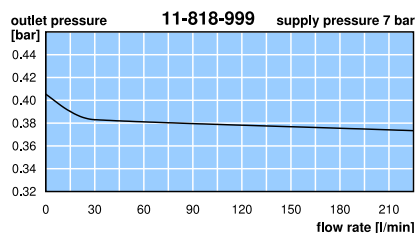

*1 at 7 bar supply pressure and 1.4 bar outlet pressure

*2 01 = 0...1 bar, 04 = 0...4 bar, 10 = 0...10 bar

Gauges: see chapter for measuring devices

PDF CAD
www.aircom.net



Order example:
11-818-999

Description	Regulator of proven reliability and durability designed for precise pressure regulation in the event of changes in flow, supply pressure and temperature. Slight exhaust sounds are normal.	
Note	To avoid leaks the mounting nut must be screwed tight.	
Media	dry, oil-free and 25 µm filtered compressed air	
Supply pressure	max. 10 bar	
Accuracy	at varying supply pressures: < 1 mbar pressure deviation at varying volume flows: < 5 mbar pressure deviation	
Air consumption	max. 2 l/min, subject to outlet pressure	
Adjustment	by handwheel with locknut, for panel mounting	Mounting position any
Relieving function	relieving, the exhaust valve's diameter is six times greater than the regulating valve's diameter	
Gauge port	G¼ or ¼" NPT on both sides of the body, identical with the connection thread	
Temperature range	0 °C to 70 °C / 32 °F to 158 °F, for appropriately conditioned compressed air down to -30 °C / -22 °F	
Material	Body: zinc die-cast Elastomer: NBR/Buna-N	Measuring capsule: beryllium copper

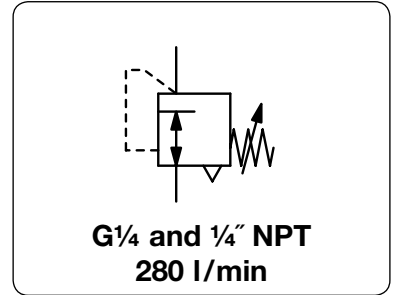

Dimensions			Description	Kv-value	Flow rate	Connection thread	Pressure range	Order number
A	B	C						
mm	mm	mm		(m³/h)	m³/h*1 l/min*1	G/NPT	bar	

Precision pressure regulator Manostat

supply pressure max. 10 bar, relieving, with constant bleed, accuracy 5 mbar									
54	70	14	standard	0.16	17	280	G¼	0.14 ... 1.7	53.1002.4X
								0.14 ... 4.0	53.1002.5X
								0.14 ... 8.0	53.1002.6X
54	70	14	standard	0.16	17	280	¼" NPT	0.14 ... 1.7	53.1002.00
								0.14 ... 4.0	53.1003.00
								0.14 ... 8.0	53.1004.00

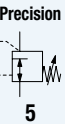

Special options, add the appropriate letter

tamper-proof cap aluminium, adjustment by screwdriver, total height 109 mm **53.1. T**

Accessories, enclosed

pressure gauge Ø 50 mm, 0...*2 bar, G¼ **MA5002-...*2**
connecting parts gauge for NPT ports, adapter ¼" NPT - G¼ female **VP-0202N**
mounting bracket made of steel, mounting nut at the device **BW11-01**

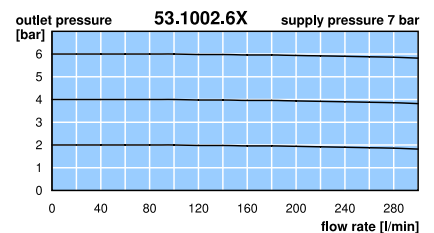
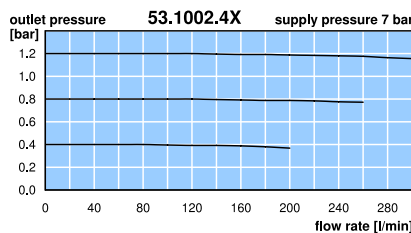
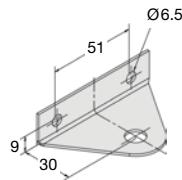
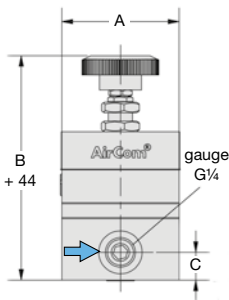
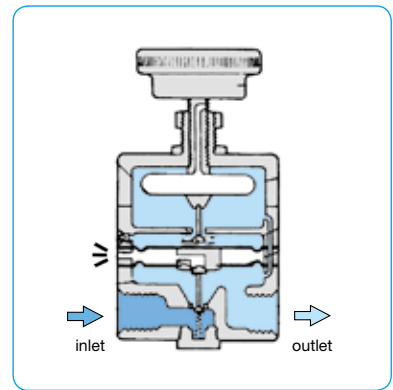

*1 at 7 bar supply pressure and 1.4 bar outlet pressure
 *2 02 = 0...2.5 bar, 04 = 0...4 bar, 10 = 0...10 bar

Gauges: see chapter for measuring devices

PDF CAD
www.aircom.net

Order example:
53.1002.4X

Description	The diaphragm pressure regulator provides precision regulation in high flow applications. A balanced inner valve, sensitive rolling diaphragm and carefully positioned aspirator tube ensure constant outlet pressure even with changing supply pressure and flow fluctuations.	
Media	compressed air or non-corrosive gases	
Supply pressure	max. 35 bar	
Accuracy	response sensitivity: < 2 mbar	
Air consumption	max. 6 l/min, subject to outlet pressure	
Adjustment	by handwheel with locknut	
Relieving function	relieving, optionally non-relieving	
Relief capacity	150 l/min at 1.5 bar outlet and 0.35 bar overpressure above setpoint	
Gauge port	G $\frac{1}{4}$ on both sides of the body, optionally $\frac{1}{4}$ " NPT	
Temperature range	0 °C to 90 °C / 32 °F to 194 °F, for appropriately conditioned compressed air down to -40 °C / -40 °F	
Material	Body: aluminium die-cast	Inner valve: stainless steel and brass
	Elastomer: NBR/Buna-N, optionally FKM	

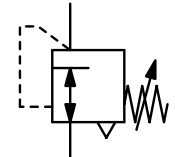

**G $\frac{1}{4}$ up to G $\frac{1}{2}$, 1000 l/min
10...140 mbar / 28 bar**

Dimensions			K _v -value (m ³ /h)	Flow rate m ³ /h*1 l/min*1	Connection thread G	Pressure range bar	Order number *
A	B	C					

Precision pressure regulator							supply pressure max. 35 bar, relieving, with constant bleed	Model 10
67	169	26	0.64	60	1000	G $\frac{1}{4}$	0.01 ... 0.14	10212H
							0.01 ... 0.7	10222H
							0.01 ... 1.4	10202H
							0.01 ... 2.1	10232H
							0.07 ... 4.1	10242H
							0.14 ... 10	10262H
							0.20 ... 14	10272H
67	178	26	0.64	60	1000	G $\frac{1}{4}$	0.30 ... 21	10282H
							0.30 ... 28	10292H



Special options, add the appropriate letter

G$\frac{3}{8}$	connection thread	102.3H
G$\frac{1}{2}$	connection thread, recommended for mbar-range	102.4H
NPT	connection thread	102.2
non-relieving	and without constant bleed	102.2.N
reduced bleeding	approx. 2 l/min	102.2.B
for small flow rate	high constant bleed for more sensitivity	102.2.L
tapped exhaust	G $\frac{1}{4}$ connection thread	102.2.E
FKM elastomer		102.2.J
tamper-proof cap	aluminium, adjustment by screwdriver, total height 166 mm	102.2.T
for oxygen	specially cleaned	102.2.SC
non-ferrous metal-free	FKM elastomer	102.2.X63

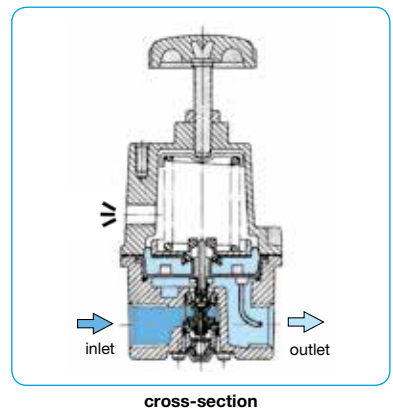

Accessories, enclosed

pressure gauge	Ø 63 mm, 0...160 mbar, G $\frac{1}{4}$, capsule type	MA6302-C2
pressure gauge	Ø 50 mm, 0...*2 bar, G $\frac{1}{4}$, Bourdon tube	MA5002-...*2
gauge connectors	for NPT ports, adapter $\frac{1}{4}$ " NPT - G $\frac{1}{4}$ female	VP-0202N
mounting bracket	made of steel	BW00-34

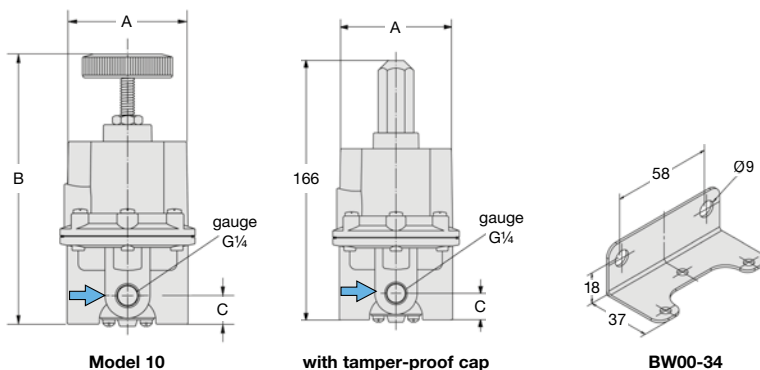
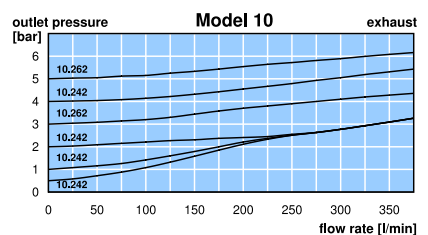
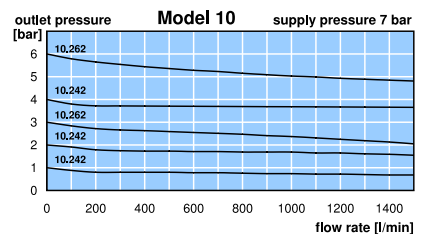

*1 at 7 bar supply pressure, 6 bar outlet pressure and 1 bar pressure drop
*2 01 = 0...1 bar, 02 = 0...2.5 bar, 06 = 0...6 bar, 10 = 0...10 bar, 16 = 0...16 bar, 25 = 0...25 bar, 60 = 0...60 bar

Gauges: see chapter for measuring devices

PDF CAD
www.aircom.net

 **Order example:
10212H**

Description	The diaphragm pressure regulator provides precision regulation in high flow applications. A balanced inner valve, sensitive rolling diaphragm and carefully positioned aspirator tube ensure constant outlet pressure even with changing supply pressure and flow fluctuations.	
Media	compressed air or non-corrosive gases	
Supply pressure	max. 17 bar	
Accuracy	response sensitivity: < 4 mbar	
Air consumption	max. 6 l/min, subject to outlet pressure	
Adjustment	by handwheel with locknut	
Relieving function	relieving, optionally non-relieving	
Relief capacity	110 l/min at 1.5 bar outlet and 0.35 bar overpressure above setpoint	
Gauge port	G $\frac{1}{4}$ on both sides of the body, optionally $\frac{1}{4}$ " NPT	
Temperature range	0 °C to 80 °C / 32 °F to 176 °F, for appropriately conditioned compressed air down to -40 °C / -40 °F	
Material	Body: aluminium die-cast Elastomer: NBR/Buna-N	Mounting position any Inner valve: stainless steel and brass

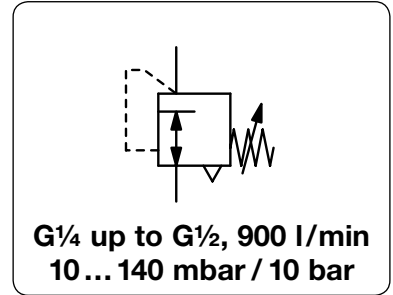

Dimensions			K _v -value (m ³ /h)	Flow rate m ³ /h*1 l/min*1	Connection thread G	Pressure range bar	Order number
A	B	C					

Precision pressure regulator							supply pressure max. 17 bar, relieving, with constant bleed	R230
67	154	16	0.5	54	900	G $\frac{1}{4}$	0.01 ... 0.14	R230-020
							0.01 ... 1.0	R230-02A
							0.01 ... 2.0	R230-02B
							0.07 ... 4.0	R230-02C
							0.14 ... 10	R230-02D



Special options, add the appropriate letter

G$\frac{3}{8}$	connection thread	R230-03 .
G$\frac{1}{2}$	connection thread, recommended for mbar range	R230-04 .
NPT	connection thread	R230-0 . .N
non-relieving	and without constant bleed	R230-0 . .K
reduced bleeding		R230-0 . .X19
tapped exhaust	connection thread G $\frac{1}{4}$	R230-0 . .X12
tamper-proof cap	aluminium, adjustment by screwdriver, total height 157 mm	R230-0 . .T
check valve	quick exhaust at supply pressure removal	R230-0 . .X80

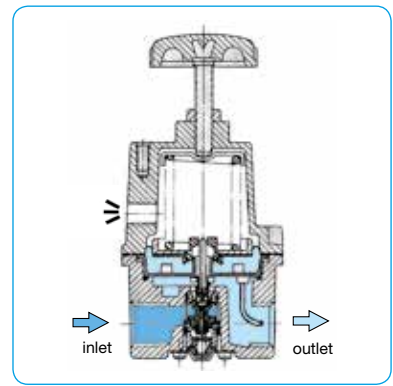

Accessories, enclosed

pressure gauge	Ø 63 mm, 0...160 mbar, G $\frac{1}{4}$, capsule type	MA6302-C2
pressure gauge	Ø 50 mm, 0...*2 bar, G $\frac{1}{4}$, Bourdon tube	MA5002-...*2
gauge connectors	NPT connection thread, adapter $\frac{1}{4}$ " NPT to G $\frac{1}{4}$ female	VP-0202N
mounting bracket	made of steel	BW00-33

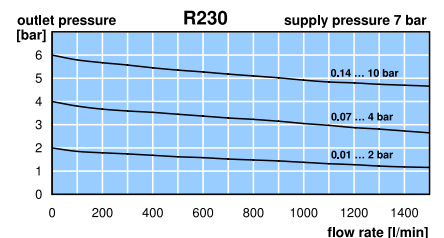
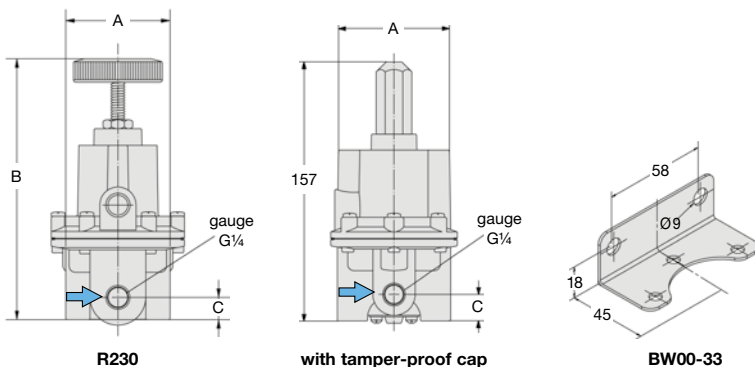

*1 at 7 bar supply pressure, 6 bar outlet pressure and 1 bar pressure drop
*2 01 = 0...1 bar, 02 = 0...2.5 bar, 06 = 0...6 bar, 10 = 0...10 bar

Description	Diaphragm pressure regulator of small and lightweight design with high flow capacity. It provides sensitive adjustment accurate to 2 mbar.	
Media	compressed air or non-corrosive gases	
Supply pressure	max. 18 bar	
Accuracy	setting accuracy:	< 2 mbar
	response sensitivity:	< 2 mbar
Air consumption	max. 3 l/min, subject to outlet pressure	
Adjustment	by handwheel with locknut	
Relieving function	relieving	
Relief capacity	55 l/min at 1.5 bar outlet and 0.35 bar overpressure above setpoint	
Gauge port	G $\frac{1}{8}$ on both sides of the body, screw plugs supplied	
Temperature range	0 °C to 90 °C / 32 °F to 194 °F, for appropriately conditioned compressed air down to -40 °C / -40 °F	
Material	Body:	aluminium die-cast
	Inner valve:	stainless steel, brass and steel
	Elastomer:	NBR/Buna-N, optionally FKM

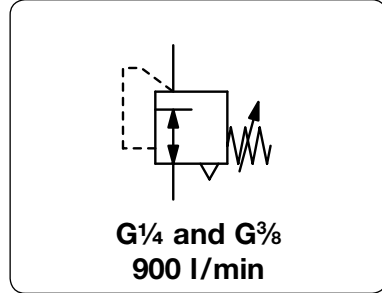

Dimensions			K _v -value (m ³ /h)	Flow rate m ³ /h*1 l/min*1	Connection thread G	Pressure range bar	Order number
A	B	C					

Precision pressure regulator							supply pressure max. 18 bar, relieving with constant bleed	R300
57	133	25	0.5	54	900	G $\frac{1}{4}$	0.001 ... 0.14	R300-020
							0.01 ... 0.7	R300-021
							0.03 ... 2.0	R300-02A
							0.07 ... 4.0	R300-02B
							0.14 ... 7.0	R300-02C
57	133	25	0.5	54	900	G $\frac{3}{8}$	0.001 ... 0.14	R300-030
							0.01 ... 0.7	R300-031
							0.03 ... 2.0	R300-03A
							0.07 ... 4.0	R300-03B
							0.14 ... 7.0	R300-03C



R300

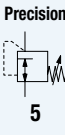

Special options, add the appropriate letter

without constant bleed	non-relieving, for small flow rate	R300-0..K
NPT	connection thread	R300-0..N
tamper-proof cap	aluminium, adjustment by screwdriver, total height 141 mm	R300-0..T
FKM elastomer		R300-0..V
for oxygen	specialy cleaned, with oxygen grease	R300-0..K15

Accessories, enclosed

pressure gauge	Ø 63 mm, 0... 160 mbar, G $\frac{1}{4}$ -connection parts required	MA6302-C2
pressure gauge	Ø 50 mm, 0...*2 bar, G $\frac{1}{8}$	MA5001-...*2
gauge connection parts	for MA6302-C2	AM-04
mounting bracket	made of steel	BW00-46

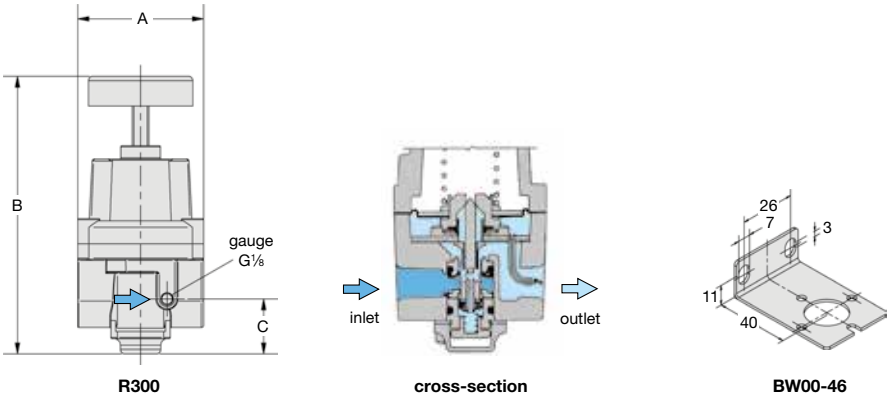
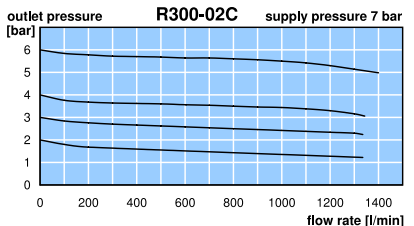
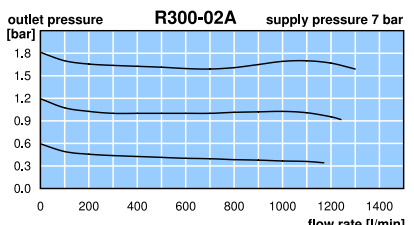
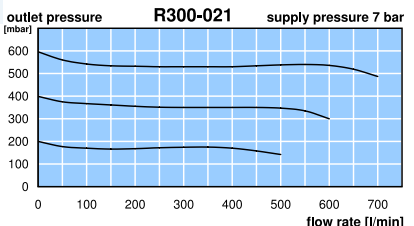
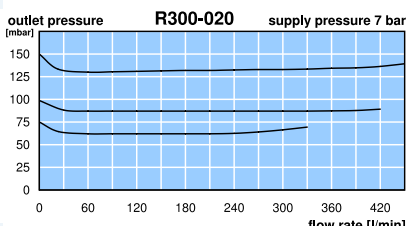

*1 at 7 bar supply pressure and 1.4 bar outlet pressure
 *2 01 = 0...1 bar, 02 = 0...2,5 bar, 04 = 0...4 bar, 10 = 0...10 bar, 16 = 0...16 bar, C2 = 160 mbar

PRECISION PRESSURE REGULATOR WITHOUT CONSTANT BLEED

R100

Description	Regulator provides precision regulation in high flow and high relief applications. A sensitive rolling diaphragm and balanced inner valve assure constant outlet pressure even with changing supply pressure and flow fluctuations.		
Media	compressed air or non-corrosive gases		
Supply pressure	max. 18 bar		
Accuracy	at supply pressure variation of 7 bar: < 7 mbar pressure deviation response sensitivity: < 2 mbar		
Air consumption	without constant bleed		
Adjustment	by handwheel with locknut		
Relieving function	relieving		
Relief capacity	200 l/min at 1.5 bar outlet and 0.35 bar overpressure above setpoint		
Gauge port	G $\frac{1}{4}$ on both sides of the body, screw plugs supplied		
Temperature range	0 °C to 80 °C / 32 °F to 194 °F, for appropriately conditioned compressed air down to -40 °C / -40 °F		
Material	Body: zinc die-cast	Inner valve: aluminium, brass and neoprene	Mounting position any Elastomer: NBR/Buna-N

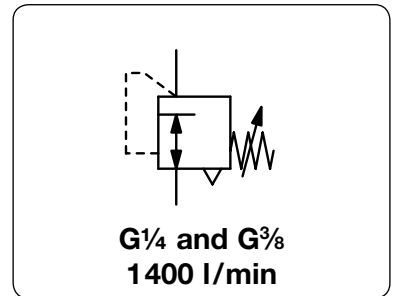

Dimensions			K _v -value (m ³ /h)	Flow rate		Connection thread G	Pressure range bar	Order number
A	B	C		m ³ /h*1	l/min*1			

Precision pressure regulator						supply pressure max. 18 bar, relieving, without constant bleed	R100
54	129	25	0.73	78	1300	G $\frac{1}{4}$	0.03 ... 0.7 0.03 ... 2.0 0.07 ... 4.0 0.14 ... 10 R100-021 R100-02A R100-02B R100-02C
54	129	25	0.78	84	1400	G $\frac{3}{8}$	0.03 ... 0.7 0.03 ... 2.0 0.07 ... 4.0 0.14 ... 10 R100-031 R100-03A R100-03B R100-03C



R100

Special options, add the appropriate letter

NPT	connection thread	R100-0. . N
tamper-proof cap	of aluminium, adjustment by screwdriver, total height 139 mm	R100-0. . T

Accessories, enclosed

pressure gauge	Ø 50 mm, 0...*2 bar, G $\frac{1}{4}$	MA5002- . . *2
mounting bracket	made of steel	BW20-04

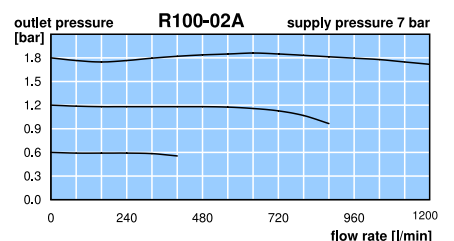
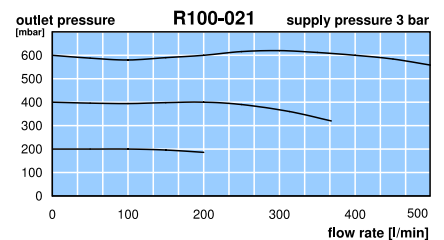
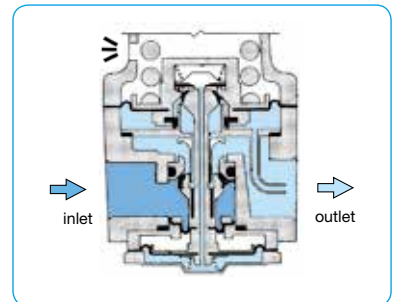
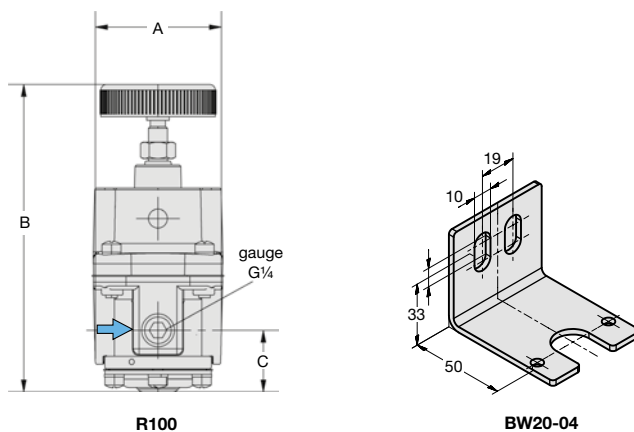

*1 at 7 bar supply pressure and 1.4 bar outlet pressure
*2 01 = 0...1 bar, 02 = 0...2.5 bar, 04 = 0...4 bar, 10 = 0...10 bar

Gauges: see chapter for measuring devices

PDF CAD
www.aircom.net



Order example:
R100-021

Description Highly sensitive, two-step precision pressure regulator working in the flapper-nozzle principle. Solid construction for low-maintenance operation with compressed air or non-corrosive gases.

Booster version In option A version the regulator can also be controlled by pilot pressure up to 7 bar in addition to range spring control. Thereby the regulator becomes a volume booster with double loop, parallel zero point shift

Supply pressure minimum: 0.3 bar above outlet pressure maximum: see chart

Air consumption Constant bleed only when flow is circulating. The greater the difference between supply and outlet pressure the greater is the air consumption, e.g. 9 bar inlet and 7 bar outlet resulting in 3 l/min air consumption.

Exhaust 50 l/min at 1.7 bar outlet pressure and 20 mbar overpressure to outlet pressure

Pressure stability 10 mbar pressure drop when changing flow rate from "0" to "max".

Setting accuracy < 0.03 % outlet pressure. Ten adjusting knob turns for the setting of the whole adjustment range.

Gauge port 1/4" NPT on both sides, screw plugs supplied **Mounting position:** any

Temperature range Operating pressure : -4 °C to 80 °C / 25 °F to 176 °F Storage temperature: -20 °C to 100 °C / -4 °F to 212 °F

Temperature sensitivity 1 % pressure deviation at temperature change of 30 K, 0.1 % deviation for isotherm spring (please inquire)

Material fluid-contact: brass, stainless steel, neoprene, aluminium and zinc

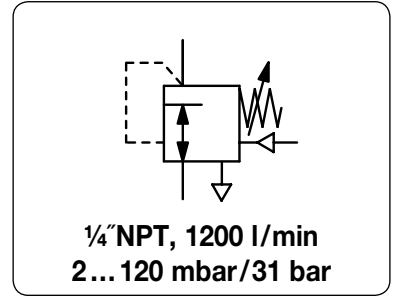

Dimensions	Flow rate	Supply pressure	Connection	Pressure range	Order number
Höhe	Ø	recommended	thread		
mm	mm	bar*2	NPT	mbar / bar	

Precision regulator "Nullmatic"						K _v = 0.16 K _v = 0.66 for version „H“	R40
189	86	300	0.7	1.7	1/4" NPT	2...120 mbar	R40-2
189	86	300	3.5	7	1/4" NPT	10...500 mbar	R40-7
189	86	300	5	10	1/4" NPT	0.03... 1 bar	R40-15
189	86	300	8	10	1/4" NPT	0.07... 2 bar	R40-30
189	86	300	8	10	1/4" NPT	0.07...3.5 bar	R40-50
189	86	1200	8	10	1/4" NPT	0.07...3.5 bar	R40-50H
189	86	300	10	35	1/4" NPT	0.1... 7 bar	R40-100
189	86	1200	10	35	1/4" NPT	0.1... 7 bar	R40-100H
192	86	300	17	35	1/4" NPT	0.2... 14 bar	R40-200
192	86	300	24	35	1/4" NPT	0.5... 21 bar	R40-300
192	86	300	35	35	1/4" NPT	1... 31 bar	R40-450



R40

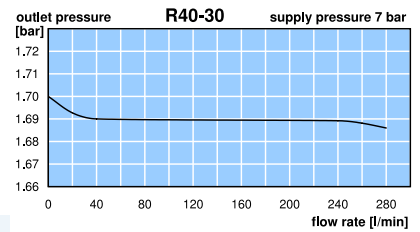

Special options, add the appropriate letter

volume booster version: up to max. 7 bar pilot pressure R40A-...

Accessories, enclosed

- pressure gauge Ø 50 mm, 0...*2 bar, G1/4 MA5002-...*3
- pressure gauge Ø 63 mm, 0... 160 mbar, G1/4-connection parts required for R40-2 MA6302-C2
- gauge connectors for NPT ports, adapter 1/4" NPT to G1/4 female VP-0202N
- mounting bracket BW20-02

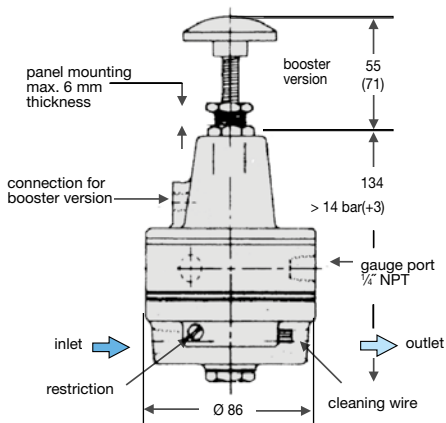
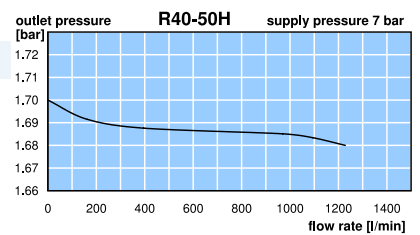

R40

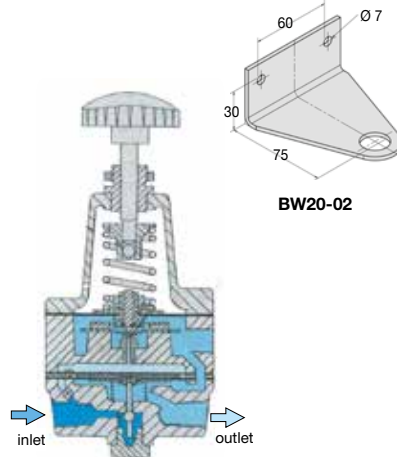

cross section

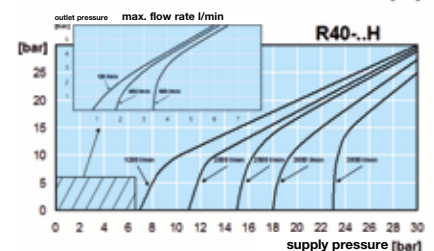
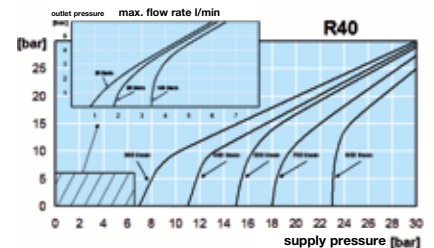

*1 at 7 bar supply pressure, 1.7 bar outlet pressure and 20 mbar pressure drop
*2 lowest outlet pressure will only be reached when applying the recommended inlet pressure
*3 01 = 0...1 bar, 02 = 0...2.5 bar, 04 = 0...4 bar, 10 = 0...10 bar, 16 = 0...16 bar, 25 = 0...25 bar, 60 = 0...60 bar

Gauges: see chapter for measuring devices

PDF CAD
www.aircom.net

Order example:
R40-2

PRECISION PRESSURE REGULATOR WITHOUT CONSTANT BLEED

R400

Description	The diaphragm regulator provides high-precision regulation in high flow and high relief applications. A sensitive rolling diaphragm and balanced inner valve ensure constant outlet pressure even with changing supply pressure and flow fluctuations.	
Media	compressed air or non-corrosive gases	
Supply pressure	max. 18 bar	
Accuracy	response sensitivity: < 2 mbar	
Air consumption	without constant bleed	
Adjustment	by handwheel with locknut	
Relieving function	relieving	
Relief capacity	1000 l/min at 1.5 bar outlet and 0.35 bar overpressure above setpoint	
Gauge port	G $\frac{1}{4}$ on both sides of the body, screw plugs supplied	
Temperature range	0 °C to 90 °C / 32 °F to 194 °F, for appropriately conditioned compressed air down to -40 °C / -40 °F	
Material	Body: aluminium die-cast	Elastomer: NBR/Buna-N, optionally FKM
	Inner valve: stainless steel, brass, aluminium and steel	

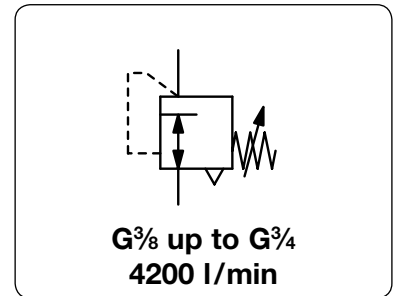

Dimensions			K _v -value (m ³ /h)	Flow rate		Connection thread G	Pressure range bar	Order number
A	B	C		m ³ /h*1	l/min*1			

Precision pressure regulator							supply pressure max. 18 bar, relieving, without constant bleed	R400
89	206	39	2.12	228	3800	G $\frac{3}{8}$	0.03 ... 0.7	R400-031
							0.03 ... 2.0	R400-03A
							0.07 ... 4.0	R400-03B
							0.15 ... 10	R400-03C
							0.35 ... 17	R400-03D
89	206	39	2.23	240	4000	G $\frac{1}{2}$	0.03 ... 0.7	R400-041
							0.03 ... 2.0	R400-04A
							0.07 ... 4.0	R400-04B
							0.15 ... 10	R400-04C
							0.35 ... 17	R400-04D
89	206	39	2.34	252	4200	G $\frac{3}{4}$	0.03 ... 0.7	R400-061
							0.03 ... 2.0	R400-06A
							0.07 ... 4.0	R400-06B
							0.15 ... 10	R400-06C
							0.35 ... 17	R400-06D

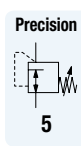

Special options, add the appropriate letter		
tapped exhaust	connection thread G $\frac{1}{4}$	R400-0 . . X12
NPT	connection thread	R400-0 . . N
tamper-proof cap	of aluminium, adjustment by screwdriver, total height 295 mm	R400-0 . . T
FKM elastomer	up to 10 bar	R400-0 . . V

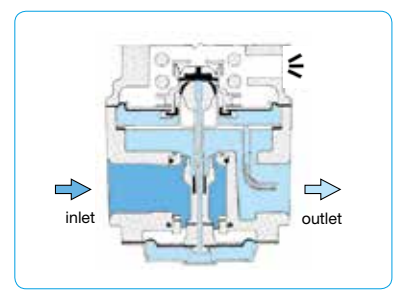

Accessories, enclosed		
pressure gauge	Ø 63 mm, 0...*2 bar, G $\frac{1}{4}$	MA6302-...*2
mounting bracket	made of steel	BW00-47

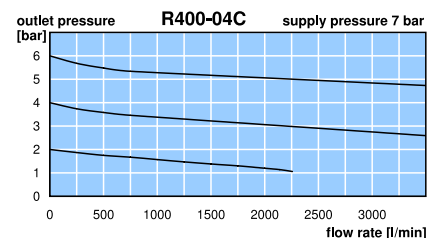
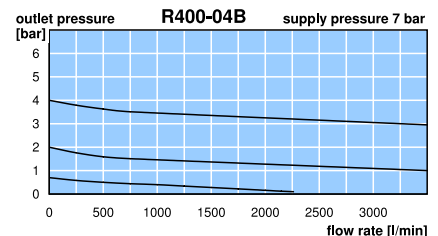
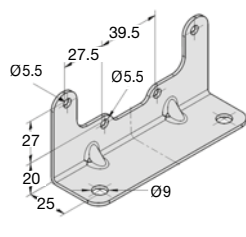
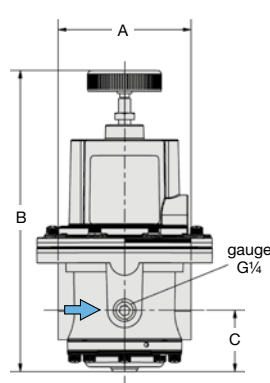

Gauges: see chapter for measuring devices

PDF CAD
www.aircom.net

Order example:
R400-031

Description	Regulator provides precision regulation in high flow and high relief applications. A sensitive rolling diaphragm and balanced inner valve ensure constant outlet pressure even with changing supply pressure and flow fluctuations. The regulator is silicone-free and suitable for panel mounting.	
Media	oil-free and 5 µm filtered compressed air or non-corrosive gases	
Supply pressure	max. 16 bar	
Accuracy	at supply pressure change from 2 bar to 7 bar: < 6 mbar pressure deviation at volume flow change from 0 l/min to 20 l/min: < 20 mbar pressure deviation response sensitivity: < 4 mbar	
Air consumption	< 1.5 l/min at P _i = 5 bar, < 2 l/min at P _i = 7 bar, < 4 l/min at P _i = 10 bar, < 1% of volume flow	
Adjustment	by handwheel with locknut, suitable for panel mounting	
Relieving function	relieving	
Relief capacity	700 l/min at 6 bar outlet and 0.35 bar overpressure above setpoint	
Gauge port	G¼ on both sides of the body, one screw plug supplied	
Temperature range	0 °C to 60 °C / 32 °F to 140 °F, for appropriately conditioned compressed air down to -35 °C / -31 °F	
Material	Body: zinc die-cast Elastomer: NBR/Buna-N	

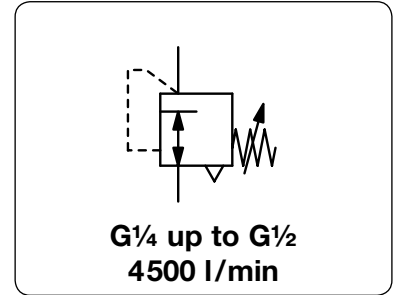

Dimensions			K _v -value (m³/h)	Flow rate		Connection thread G	Pressure range bar	Order number
A	B	C		m³/h*1	l/min*1			

Precision pressure regulator								supply pressure max. 16 bar, relieving, with constant bleed	R03
82	200	41	2.1	198	3300	G¼*3	0.01 ... 3	R03-02A	
							0.02 ... 5	R03-02B	
							0.04 ... 7	R03-02C	
							0.05 ... 10	R03-02D	
82	200	41	2.4	228	3800	G¾*3	0.01 ... 3	R03-03A	
							0.02 ... 5	R03-03B	
							0.04 ... 7	R03-03C	
							0.05 ... 10	R03-03D	
82	200	41	2.9	270	4500	G½	0.01 ... 3	R03-04A	
							0.02 ... 5	R03-04B	
							0.04 ... 7	R03-04C	
							0.05 ... 10	R03-04D	



R03

Special options, add the appropriate letter

tamper-proof cap total height 204 mm R03-0..T

Accessories, enclosed

pressure gauge Ø 50 mm, 0...*2 bar, G¼ **MA5002-...*2**
mounting bracket made of steel **BW00-36**

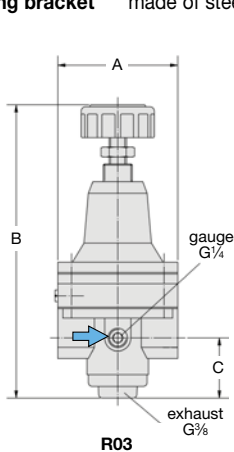

R03

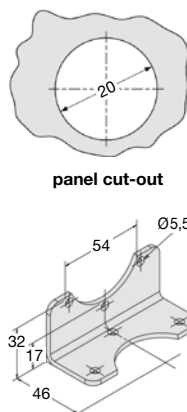

panel cut-out

BW00-36

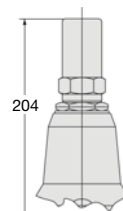

tamper-proof cap

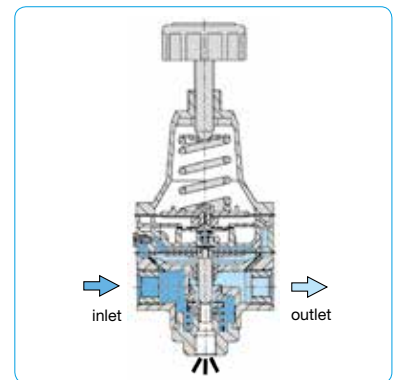

cross-section

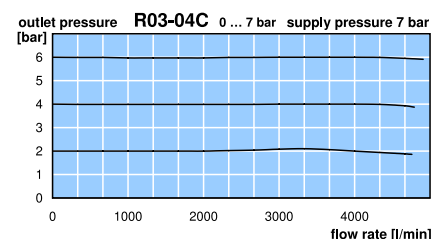
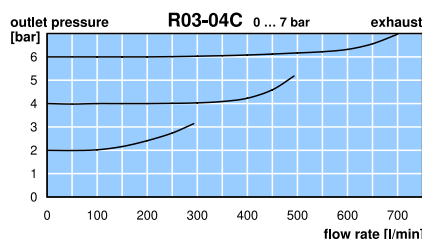
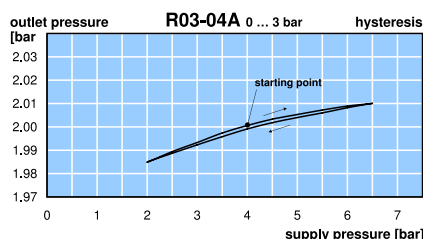

*1 at 7 bar supply pressure and 6 bar outlet pressure

*2 04 = 0...4 bar, 06 = 0...6 bar, 10 = 0...10 bar

*3 standard unit G½ is reduced to smaller threads by fittings

Gauges: see chapter for measuring devices

PDF CAD
www.aircom.net



Order example:
R03-02A

Description	Diaphragm regulator with small dimensions. Suitable for low pressure applications, with high relief capacity. A sensitive rolling diaphragm ensure constant outlet pressure even with changing supply pressure and flow fluctuations.	
Media	compressed air or non-corrosive gases	
Recommendation	connection thread G $\frac{1}{2}$ for pressure range 0...35 / 140 / 280 mbar	
Supply pressure	max. 10 bar	
Accuracy	response sensitivity: < 0,2 mbar	Air consumption max. 2 l/min depending on outlet pressure
Adjustment	by handwheel with locknut	
Relieving function	relieving, optionally non-relieving	Relief capacity 14 l/min at 7 mbar above setpoint 70 mbar
Gauge port	G $\frac{1}{4}$ on both sides of the body, optionally $\frac{1}{4}$ NPT	
Mounting position	any	
Temperature range	0 °C to 90 °C / 32 °F to 194 °F, for appropriately conditioned compressed air down to -40 °C / -40 °F	
Material	Body: aluminium die-cast Inner valve: stainless steel and galvanised steel Elastomer: NBR/Buna-N, optionally FKM	

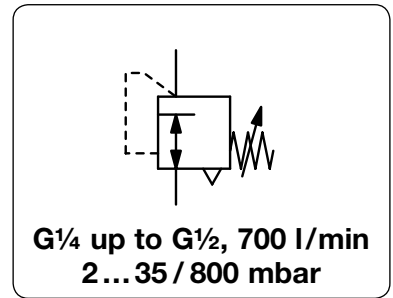

Dimensions			K _v -value (m ³ /h)	Flow rate		Connection thread G	Pressure range mbar	Order number
A	B	C		m ³ /h*1	l/min*1			

Precision regulator for low pressure								supply pressure max. 10 bar, relieving, with constant bleed	R110
67	180	25	0,4	42	700	G $\frac{1}{4}$	2... 35	R110-020	
							2... 140	R110-02A	
							2... 280	R110-02B	
							2... 400	R110-02C	
							2... 800	R110-02D	
67	180	25	0,4	42	700	G $\frac{1}{2}$	2... 35	R110-040	
							2... 140	R110-04A	
							2... 280	R110-04B	
							2... 400	R110-04C	
							2... 800	R110-04D	

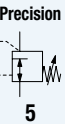

Special options, add the appropriate letter		
G $\frac{3}{8}$	connection thread	R110-03 .
NPT	connection thread	R110-0 . .N
non-relieving	without constant bleed	R110-0 . .K
reduced bleeding	ca. 1 l/min	R110-0 . .X19
tapped exhaust	connection thread G $\frac{1}{4}$	R110-0 . .X12
FKM elastomer		R110-0 . .V
tamper-proof cap	aluminium, adjustment by screwdriver, total height 183 mm	R110-0 . .T

Accessories, enclosed		
pressure gauge	Ø 63 mm, 0... *2 mbar, G $\frac{1}{4}$, capsule type	MA6302-... *2
	Ø 63 mm, 0...600mbar, G $\frac{1}{4}$, Bourdon tube	MA6302-C6
	Ø 63 mm, 0... 1 bar, G $\frac{1}{4}$, Bourdon tube	MA6302-01
gauge connectors	NPT connection thread, adapter $\frac{1}{4}$ " NPT to G $\frac{1}{4}$ female	VP-0202N
mounting bracket	made of steel	BW00-58

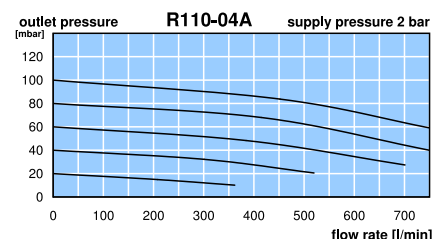
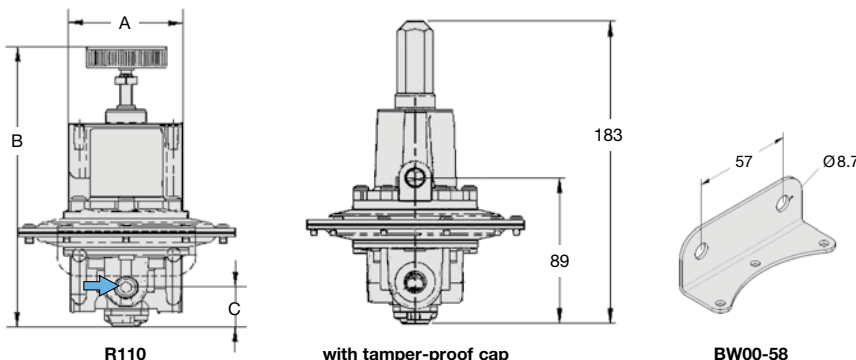
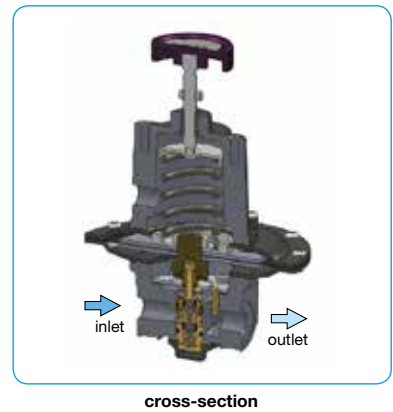

*1 at 7 bar supply pressure, 800 mbar outlet pressure and 40 mbar pressure drop
*2 B6 = 0...60 mbar, C2 = 0...160 mbar, C3 = 0...250 mbar, C4 = 0...400 mbar

Description	Provides precision regulation in high flow and high relief applications. A sensitive rolling diaphragm and balanced inner valve assure constant outlet pressure even with supply pressure and flow fluctuations.	
Media	compressed air or non-corrosive gases	
Supply pressure	max. 18 bar, optionally max. 35 bar	
Accuracy	response sensitivity: < 2 mbar	
Air consumption	0.5% of volume flow, max. 15 l/min	
Adjustment	by T-handle with locknut	
Relieving function	relieving, optionally non-relieving	
Relief capacity	1200 l/min at 1.5 bar outlet and 0.35 bar overpressure above setpoint	
Gauge port	G¼ for outlet pressure	Mounting position any
Temperature range	0 °C to 90 °C / 32 °F to 194 °F, for appropriately conditioned compressed air down to -40 °C / -40 °F	
Material	Body: aluminium die-cast Elastomer: NBR/Buna-N, optionally FKM at 35 bar version Inner valve: stainless steel, brass, aluminium and steel	

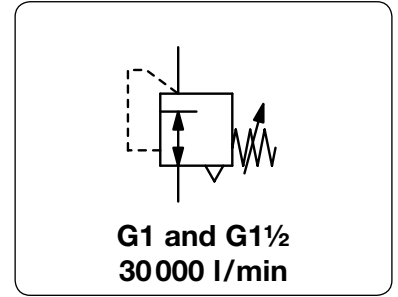

Dimensions			K _v -value (m³/h)	Flow rate m³/h*1 l/min*1	Connection thread G	Pressure range bar	Order number
A	B	C					

Precision pressure regulator							supply pressure max. 18 bar, relieving, with constant bleed	R102
141	287	56	11.4	1680	28000	G1	0.001 ... 0.7	R102-081
							0.03 ... 2.0	R102-08A
							0.07 ... 4.0	R102-08B
							0.14 ... 7.0	R102-08C
							0.14 ... 10	R102-08D
141	287	56	12.2	1800	30000	G1½	0.001 ... 0.7	R102-121
							0.03 ... 2.0	R102-12A
							0.07 ... 4.0	R102-12B
							0.14 ... 7.0	R102-12C
							0.14 ... 10	R102-12D



R102

Special options, add the appropriate letter

NPT	connection thread	R102-... N
non-relieving	and without constant bleed	R102-... K
supply pressure 35 bar	free of non-ferrous metal, FKM elastomer	R102-... X62
tamper-proof cap	aluminium, adjustment by screwdriver, total height 295 mm	R102-... T

Accessories, enclosed

pressure gauge	Ø 63 mm, 0...*2 bar, G¼	MA6302-...*2
mounting bracket	made of steel	BW00-30

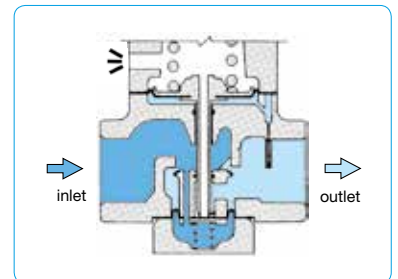

cross-section

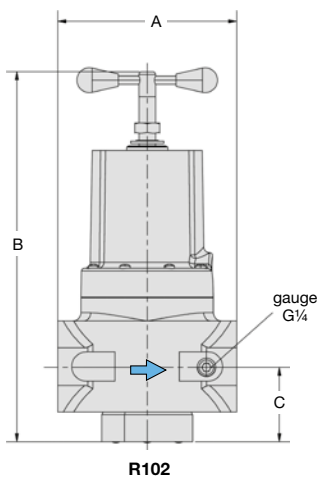

R102

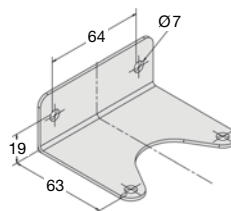

BW00-30

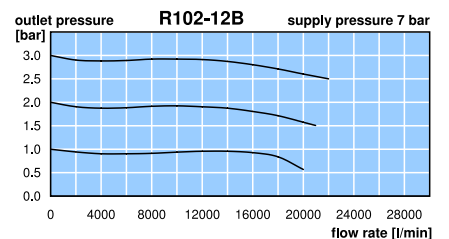
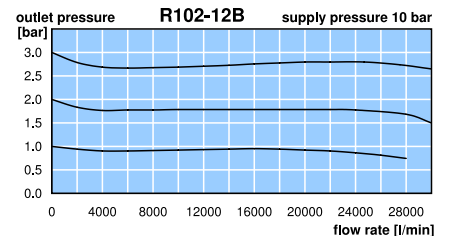

*1 at 10 bar supply pressure and 2.8 bar outlet pressure
*2 01 = 0...1 bar, 02 = 0...2.5 bar, 04 = 0...4 bar, 10 = 0...10 bar

Gauges: see chapter for measuring devices

PDF CAD
www.aircom.net

Order example:
R102-081